

SG301-SF2SNM Ground plane omni, 0 dBd, 450-470 MHz

Also referred as: SRL301NM*2

- Covers upto 20 MHz bandwidth without adjustment
- Rugged construction, light weight and easy to install

The SG301 is a versatile antenna ideal for use where broadband, unity gain, omnidirectional coverage is needed. It covers a 20 MHz bandwidth without adjustment. Its rugged construction, light weight and ease of installation make it an ideal choice for RCC leased or rented system use. Because of its bandwidth it can be stocked for re-use or re-sale.

Application Notes

- For use in broadband applications such as transportation, agriculture, forestry and mining. Unity gain with omnidirectional coverage provides increased flexibility.

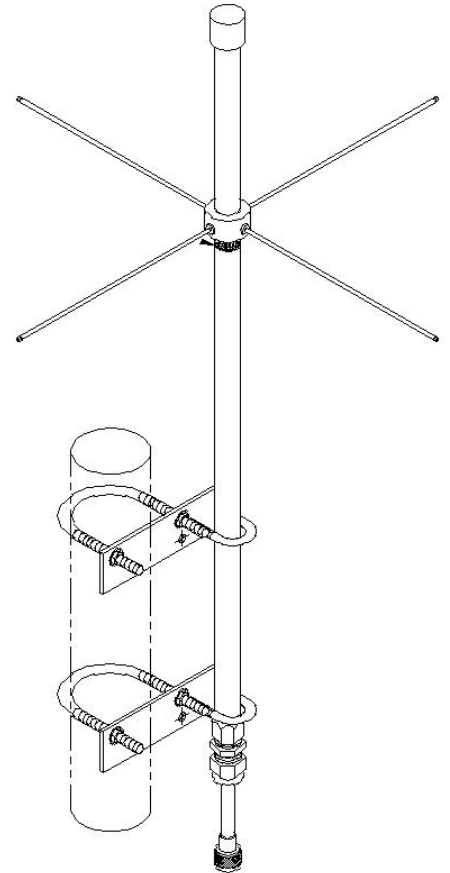

www.sinctech.com

Region	United States	Europe, Middle East and Africa	Caribbean and Latin America	Canada and rest of the world
Telephone	USA: 1 800 263 3275	International: +44 (0) 1487 84 28 19	International: +1 905 726 7676	Canada: 1 800 263 3275 International: +1 905 727 0165
E-mail	salesusa@sinctech.com	salesuk@sinctech.com	salesla@sinctech.com	salescan@sinctech.com

Electrical Specifications

Frequency Range	MHz	450 to 470
Bandwidth	MHz	20
Connector		N-Male
Gain (nominal)	dBd (dBi)	unity (2.1)
Input VSWR (max)		1.5:1
Polarization		vertical
Impedance	Ω	50
Pattern		Omni-directional
Vertical beamwidth (typ)	degrees	87
Average Power Input (max)	W	100
Lightning protection		DC ground

Mechanical Specifications

Width	in (mm)	16 (406)
Depth	in (mm)	16 (406)
Length/ Height	in (mm)	23 (584)
Base pipe diameter	in (mm)	0.75 (19)
Base pipe mounting length	in (mm)	8 (203)
Weight	lbs (kg)	2 (0.91)
Mounting Hardware (Included)		Clamp135
Actual shipping weight	lbs (kg)	5 (2.27)
Shipping dimensions	in (mm)	3x5x25 (76x127x635)

Environmental Specifications

Temperature range	°F (°C)	-40 to +140 (-40 to +60)
Wind Loading Area (Flat Plate Equivalent)	ft ² (m ²)	0.09 (0.01)
Wind Loading Area (1/2" ice)	ft ² (m ²)	0.33 (0.03)
Rated wind velocity (no ice)	mph (km/h)	100 (161)
Rated wind velocity (1/2" radial ice)	mph (km/h)	85 (137)
Lateral thrust (100 mph No Ice)	lbs (N)	3.4 (15.3)
Bending moment (100 mph No Ice)	ft-lbs (Nm)	0.52 (0.7)

Ordering Information

Clamps included.

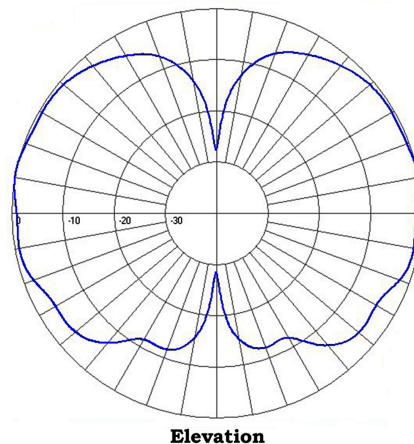

Region	United States	Europe, Middle East and Africa	Caribbean and Latin America	Canada and rest of the world
Telephone	USA: 1 800 263 3275	International: +44 (0) 1487 84 28 19	International: +1 905 726 7676	Canada: 1 800 263 3275 International: +1 905 727 0165
E-mail	salesusa@sinctech.com	salesuk@sinctech.com	salesla@sinctech.com	salescan@sinctech.com